

PS-5100

AEP Model

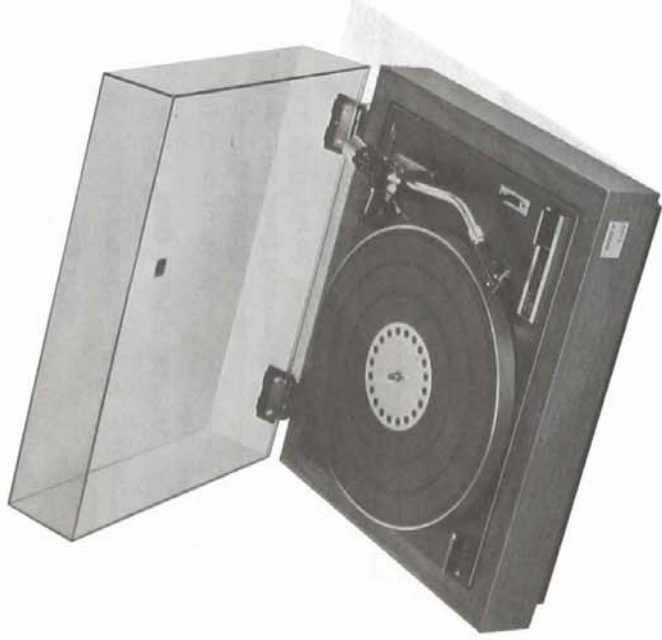

STEREO TURNTABLE SYSTEM

SPECIFICATIONS

GENERAL

Speeds: 33 ¹/₃, 45 rpm
Drive system: belt-drive
Wow and flutter: Less than ±0.09 % weighted (DIN 45507)
Signal-to-noise ratio: Greater than 63 dB weighted (DIN 45544)
Turntable platter: 30 cm (11 ¹/₃ ¹/₁₆ inch) dia, die-cast aluminum alloy, 1 kg (2 lb 3 oz)
Motor: 4-pole hysteresis synchronous
Power requirements: 110, 127, 220, 240 V adjustable, 50/60 Hz
Power consumption: 14 watts
Dimensions: 450 (w) x 175 (h) x 395 (d) mm
17 ³/₄ (w) x 6 ⁷/₈ (h) x 15 ⁹/₁₆ (d) inches
Net weight: 8.3 kg (18 lb 5 oz)
Shipping weight: 10.2 kg (22 lb 7 oz)

TONEARM (PUA-305)

Type: Statically balanced
Arm length: 295 mm (11 ⁵/₈ inches), overall
216.5 mm (8 ¹/₂ inches), pivot-to-stylus
Overhang: 16.5 mm (²/₃ inches)
Stylus-force adjustment range: 0 to 3 g, 0.5 g increments

Anti-skating

force compensation range: 0 to 3 g, 0.5 g increments

Cartridge weight range: 4 to 12 g

Shell head weight: 10.5 g

CARTRIDGE (VM-26G)

Type: Stereo induced magnet (IM)

Output voltage: 4 mV at 1 kHz, 5 cm/sec.

Load impedance: 50 k ohms

Frequency response: 15 Hz to 22 kHz

Channel separation: 25 dB at 1 kHz

Channel balance: 1 dB at 1 kHz

Optimum stylus force: 2 g

Stylus: Conical 0.5 mil diamond
(SONY ND-132G)

Weight: 6.8 g

SONY®

SERVICE MANUAL

TABLE OF CONTENTS

| <u>Section</u> | <u>Title</u> | <u>Page</u> |
|----------------|--|-------------|
| 1. | TECHNICAL DESCRIPTION | |
| 1-1. | Operating Instructions | 1 |
| 2. | DISASSEMBLY AND REPLACEMENT | |
| 2-1. | Top Cover Removal | 2 |
| 2-2. | Turntable Base Removal | 2 |
| 2-3. | Turntable Shaft Removal | 3 |
| 2-4. | Turntable Thrust Bearing Replacement | 3 |
| 2-5. | Main Cam Replacement | 3 |
| 2-6. | Stylus Tip Replacement | 4 |
| 2-7. | Cartridge Replacement | 4 |
| 2-8. | Tonearm Replacement | 5 |
| 2-9. | Motor Replacement | 5 |
| 3. | ADJUSTMENTS | |
| 3-1. | Tonearm Height Adjustment | 7 |
| 3-2. | Automatic Return Position Adjustment | 7 |
| 3-3. | Stylus Force Adjustment | 8 |
| 3-4. | Anti-Skating Force Adjustment | 8 |
| 3-5. | Microswitch Position Adjustment | 9 |
| 4. | MAINTENANCE | |
| 4-1. | Adaptation to Local Line Frequency | 10 |
| 4-2. | Lubrication | 10 |
| 5. | REPACKING | 11 |
| 6. | DIAGRAMS | |
| 6-1. | Mounting/Wiring Diagram | 12 |
| 6-2. | Schematic Diagram | 13 |
| 7. | EXPLODED VIEWS | 14 |
| 8. | ELECTRICAL PARTS LIST | 18 |

SECTION 1 TECHNICAL DESCRIPTION

1-1. OPERATING INSTRUCTIONS

(See Fig. 1-1 and 1-2.)

To Play Automatically

1. Place a record onto the turntable.
2. Set the speed selector knob to the desired speed.
3. Set the cueing lever to "▼".
4. Release the tonearm from its rest. Now the turntable will start rotating.
5. Bring the tonearm to the desired position of record.
6. Set the cueing lever to "▼".

Note: The cueing device also can raise or lower the tonearm at any selected point.

7. After playing the record, the tonearm will return to its rest and the unit will shut off automatically.

To Reject

To reject a record at any position when the unit is in operation, move the reject knob to "REJECT". The tonearm will return to its rest and the unit will shut off automatically.

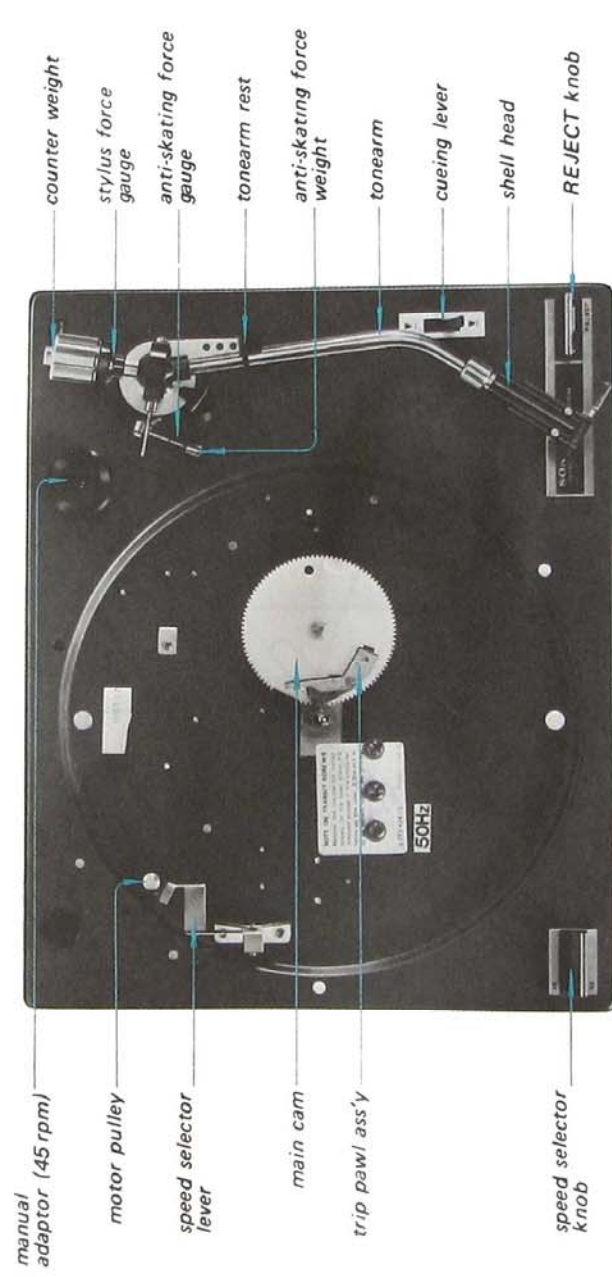

Fig. 1-1. Top view

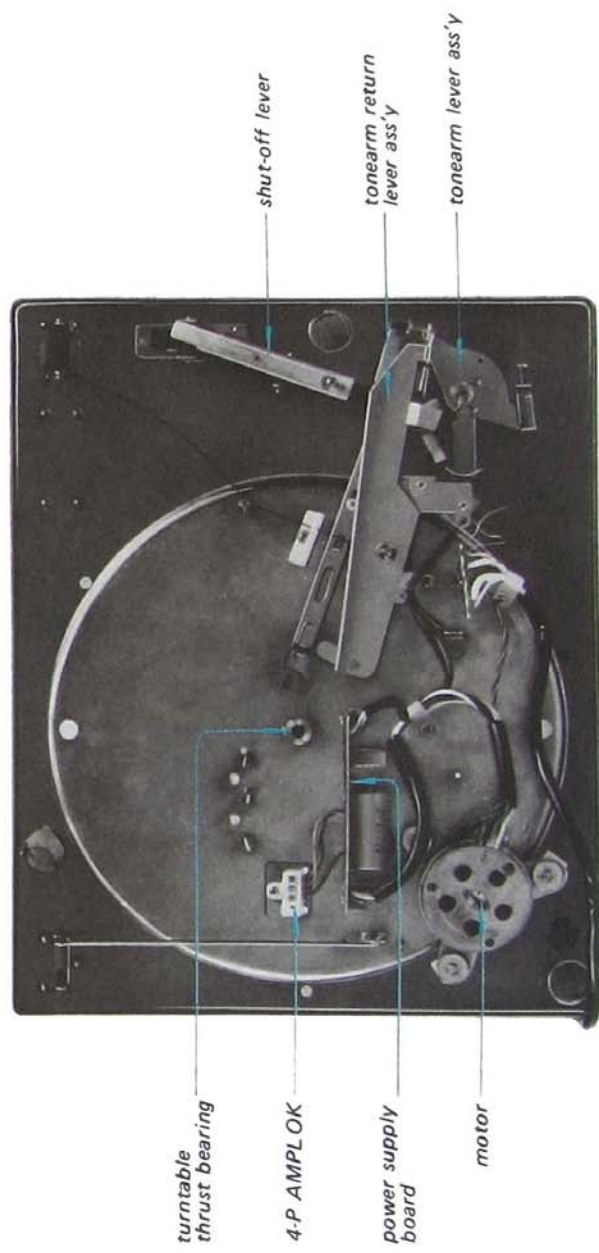

Fig. 1-2. Bottom view

SECTION 2 DISASSEMBLY AND REPLACEMENT

Note: All screws in this service manual are Phillips type (cross recess type) unless otherwise indicated.
(-) : Slotted head

2-1. TOP COVER REMOVAL

Open the top cover, and push the upper hinge toward the left to release the lock, and carefully lift the top cover straight up as shown in Fig. 2-1.

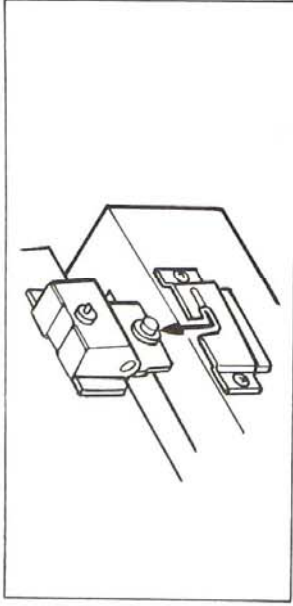

Fig. 2-1. Top cover removal

2-2. TURNTABLE BASE REMOVAL

1. Remove the rubber mat from the turntable platter and unhook the drive belt from the motor pulley.
2. Insert your both thumbs into the two holes of the turntable as shown in Fig. 2-2.

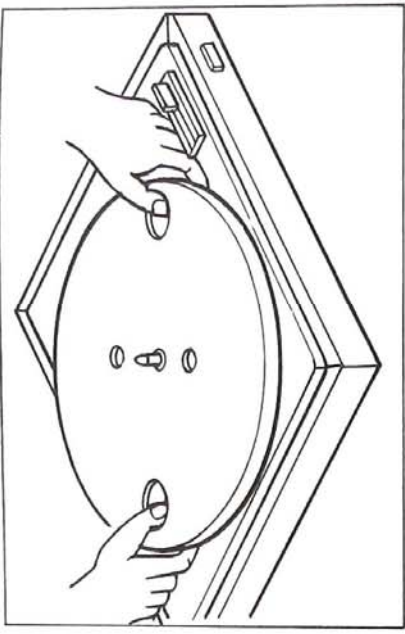

Fig. 2-2. Turntable platter removal

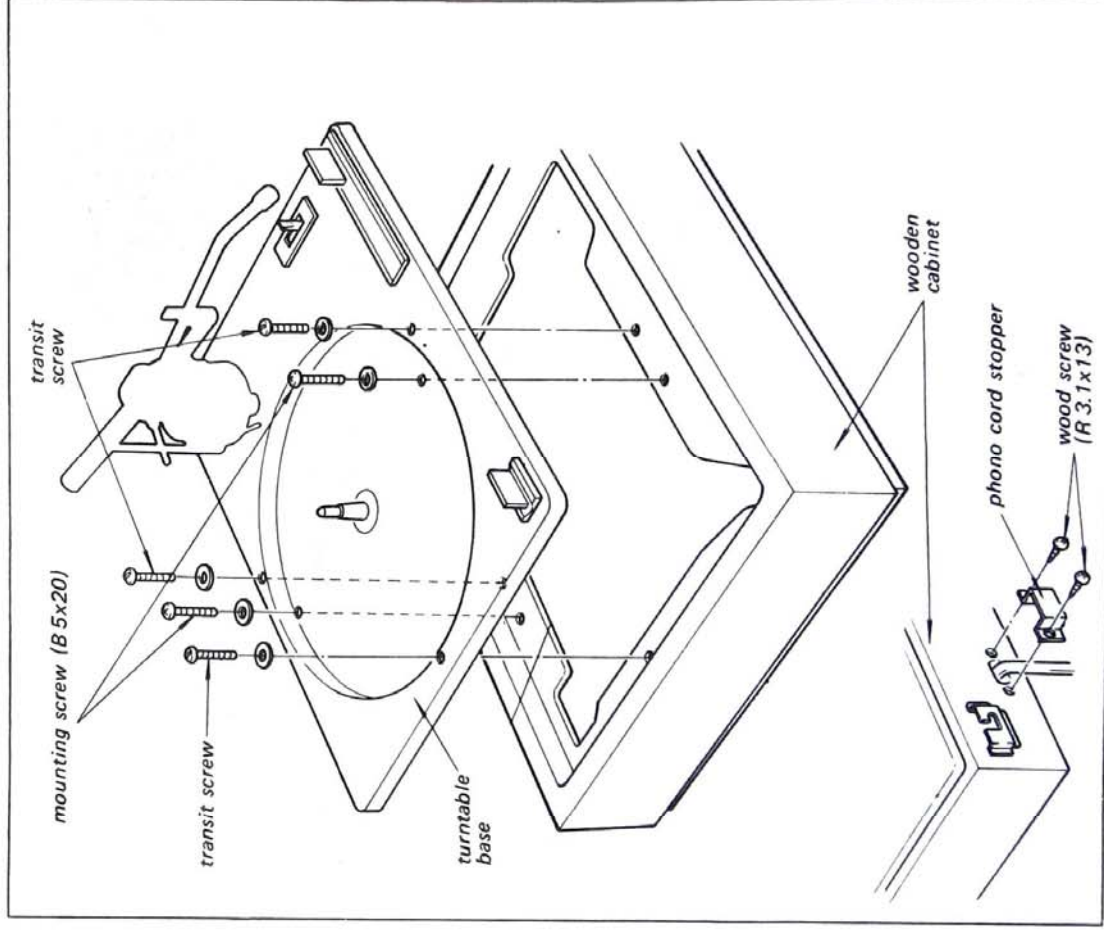

Fig. 2-3. Turntable base removal

3. Carefully lift the turntable platter straight up.
4. Remove the three transit screws and the two mounting screws shown in Fig. 2-3.
5. Remove the phono cord stopper by removing the two wood screws as shown in Fig. 2-3. This frees the phono cord.
6. Carefully lift the turntable base, and disconnect the 4-P amplok. This frees the turntable base.

2-4. TURNTABLE THRUST BEARING REPLACEMENT

1. Remove the turntable base as described in Procedure 2-2.
2. Remove the turntable shaft as described in Procedure 2-3.
3. Remove the nut and washer as shown in Fig. 2-4.
4. Install a new one.

2-3. TURNTABLE SHAFT REMOVAL

1. Remove the turntable base as described in Procedure 2-2.
2. Trip the turntable base upside down. Place a support between the turntable base and the service bench to keep pressure off tonearm.
3. Pull out the turntable shaft by removing the set screw as shown in Fig. 2-4.
4. Apply grease (Part No. 7-662-001-11) on the turntable shaft as shown in Fig. 2-4, when reinstalling it.

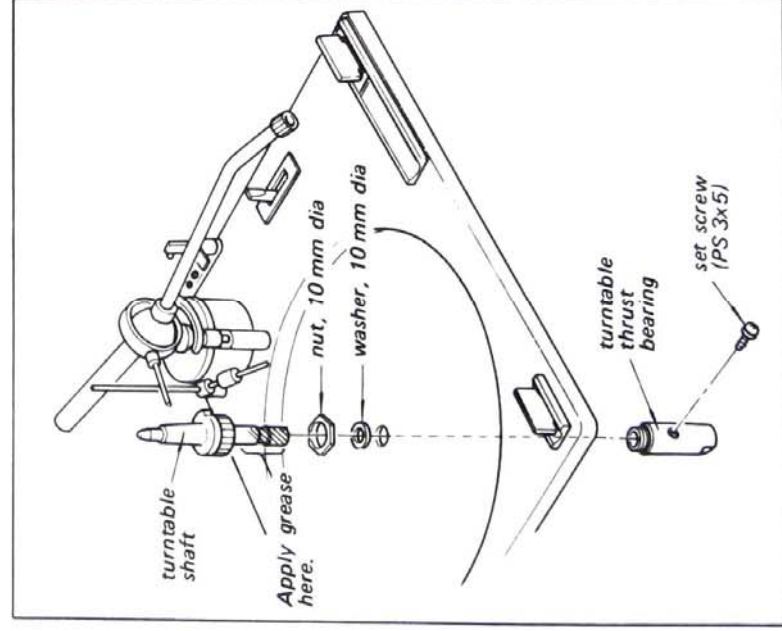

Fig. 2-4. Turntable shaft and turntable thrust bearing removal

2-5. MAIN CAM REPLACEMENT

1. Remove the retaining ring as shown in Fig. 2-5.
2. Remove the defective main cam.
3. Install a new one.

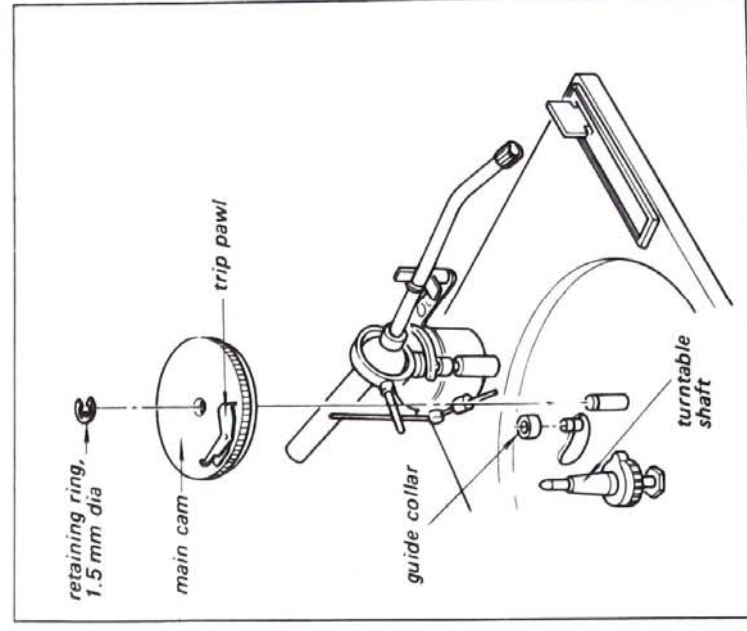

Fig. 2-5. Main cam removal

2-6. STYLUS TIP REPLACEMENT

1. Remove the shell head from the tonearm by loosening the collar as shown in Fig. 2-6.
2. Pull off the worm-stylus tip in the arrow direction as shown in Fig. 2-7, and insert the new stylus (ND-132G) into the cartridge.

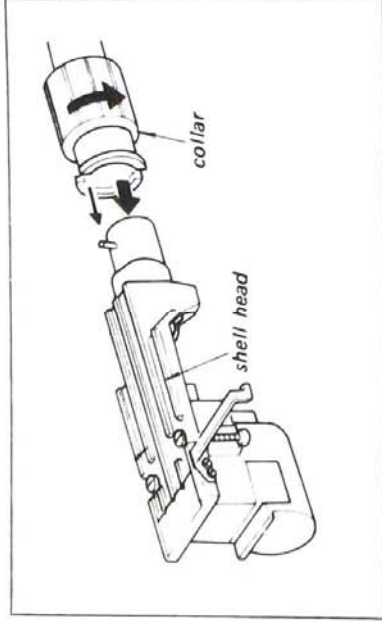

Fig. 2-6. Shell head removal.

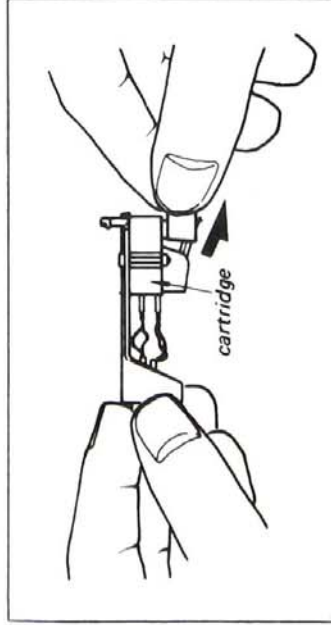

Fig. 2-7. Stylus tip replacement

2-7. CARTRIDGE REPLACEMENT

1. Remove the shell head from the tonearm by loosening the collar as shown in Fig. 2-6.
2. Unplug the four-pin connectors at the cartridge as shown in Fig. 2-8.

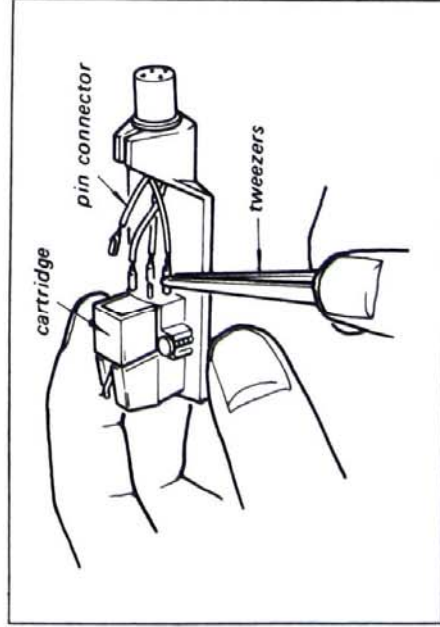

Fig. 2-8. Lead wire removal

3. Loosen the two cartridge mounting screws shown in Fig. 2-9 until the cartridge is free.
4. Remove the defective cartridge, and install the new cartridge. Refer to the wiring diagram shown in Fig. 2-10, when installing it.

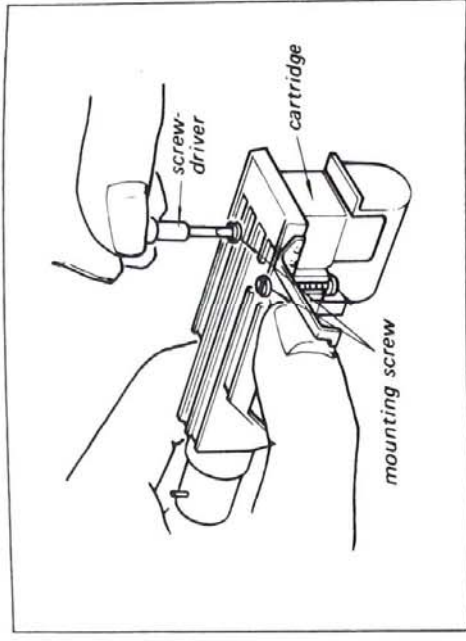

Fig. 2-9. Cartridge removal

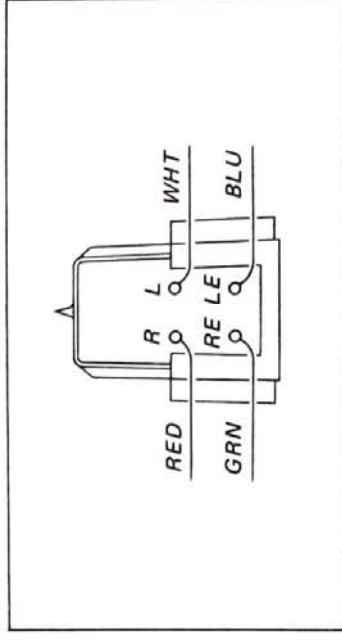

Fig. 2-10. Wiring diagram

5. Check whether or not the stylus overhang is set correctly as follows:
 - a) Loosen the adjustment screw with a screwdriver as shown in Fig. 2-11.
 - b) Slide the shell head to a position which is 52.5 mm ($2\frac{1}{16}$ ") away from the stylus tip to the end of the shell head as shown in Fig. 2-11.
 - c) Insert the Alignment Protractor supplied into the spindle through the hole on its corner.
 - d) Bring the tonearm above the cross point of the two fine lines, and carefully lower the stylus on the cross point.
 - e) Check to see that the shell head is parallel to the thick lines drawn on the Alignment Protractor as shown in Fig. 2-12. When they are parallel, the stylus overhang is set correctly.

- f) If the shell head is not parallel, adjust the stylus overhang until it is parallel.
- g) Tighten the adjustment screw.
- h) After completing the above adjustment, adjust the stylus force adjustment according to the Procedure 3-3 on page 8.

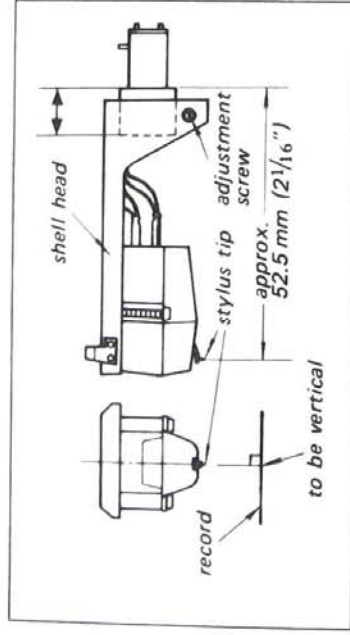

Fig. 2-11. Shell head position adjustment

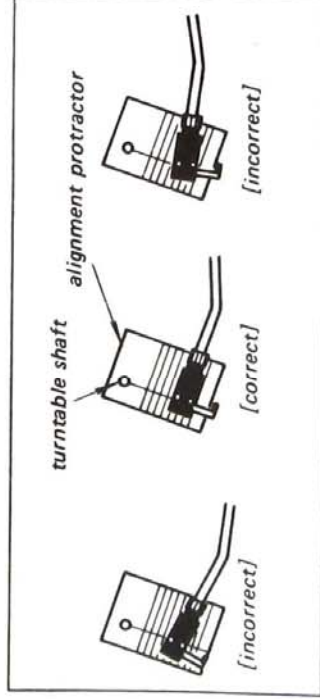

Fig. 2-12. Overhang adjustment

2-8. TONEARM REPLACEMENT

1. Remove the turntable base as described in Procedure 2-2.
2. Remove the shell head from the tonearm by loosening the collar as shown in Fig. 2-6.
3. Remove the counter weight from the tonearm.
4. Unsolder the five output-lead wires of tonearm. Refer to Fig. 2-13 when reconnecting the lead wires to the terminal strip.
5. Remove the tonearm lever ass'y by loosening the two allen-head screws as shown in Fig. 2-14.
6. Remove the hexagon-nut securing the tonearm to the turntable base as shown in Fig. 2-14.
7. Install the new tonearm.
8. After completing the tonearm replacement, make the automatic return position adjustment as described in Procedure 3-2 on page 7.

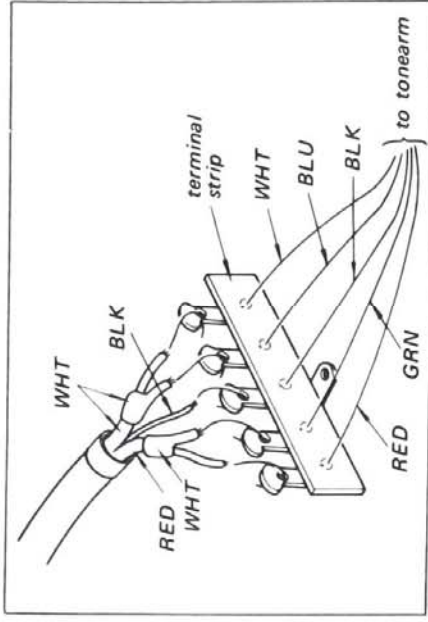

Fig. 2-13. Lead wire connection

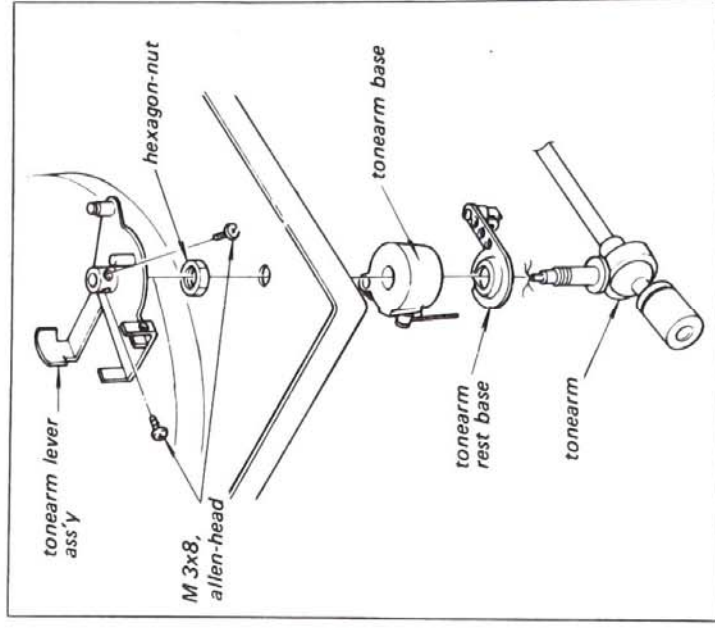

Fig. 2-14. Tonearm replacement

2-9. MOTOR REPLACEMENT

1. Remove the turntable base as described in Procedure 2-2.
2. Remove the motor pulley by loosening the set screw.
3. Unsolder the four lead wires of the motor at the power supply board.

4. Remove the lead wire clamp by removing the self-tapping screw shown in Fig. 2-15.
5. Remove the motor bracket along with the motor by removing the three retaining rings and three washers as shown in Fig. 2-15.
6. Remove the motor in the arrow direction in Fig. 2-16 by loosening the motor mounting screw.
7. Install a new motor.
8. Adjust the height of the motor by moving the motor up and down so that the top of motor is 2 mm ($\frac{5}{64}$ ") lower than bottom part of motor bracket as shown in Fig. 2-16.
9. Tighten the motor mounting screw.

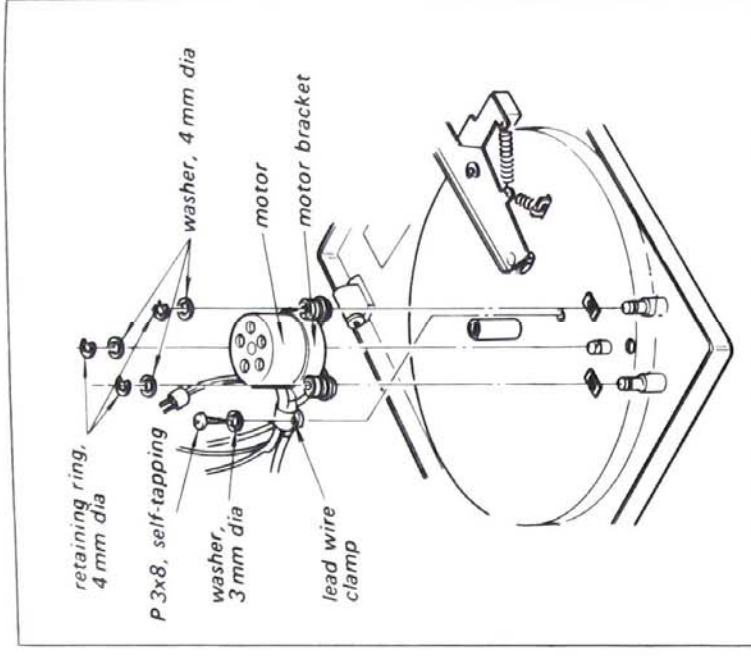

Fig. 2-15. Motor removal

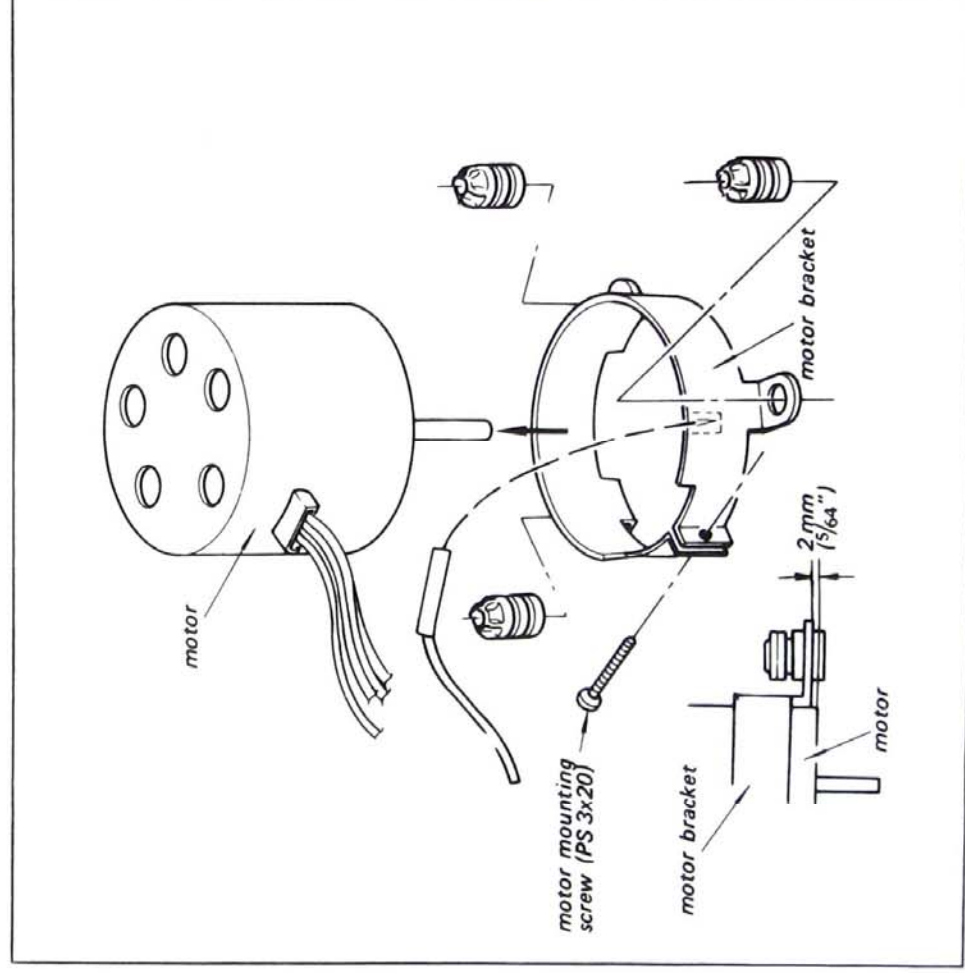

Fig. 2-16. Motor replacement

SECTION 3 ADJUSTMENTS

3-1. TONEARM HEIGHT ADJUSTMENT

At Automatic Return Operation

1. When the tonearm automatically returns to its tonearm rest after playing, check to see that the clearance between the stylus tip and the record on the turntable is 4 to 10 mm ($6/32$ " to $25/64$ ") as shown in Fig. 3-1.
2. If necessary, adjust the height of the tonearm lifting platform by loosening the its adjustment screw shown in Fig. 3-2.

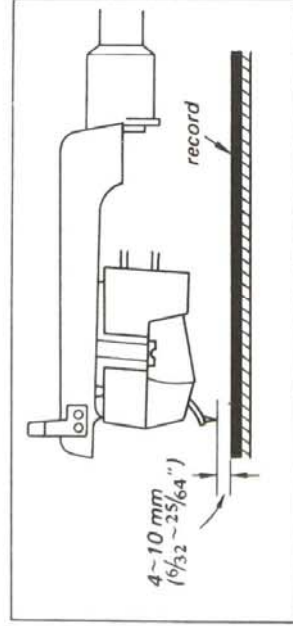

Fig. 3-1. Tonearm height adjustment (1)

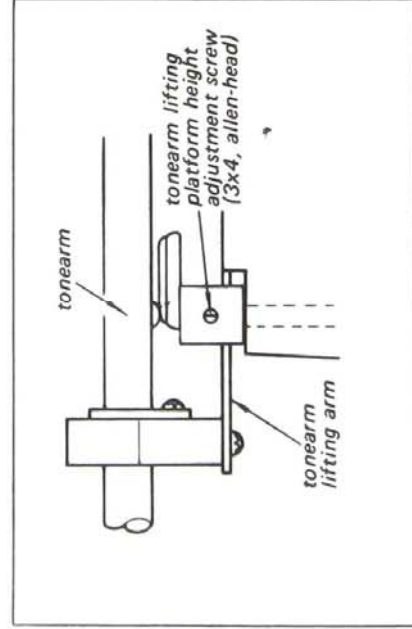

Fig. 3-2. Tonearm height adjustment (2)

At Manual Cueing Operation

1. Set the cueing lever to "V" position.
2. Confirm that the clearance between the stylus tip and the record on the turntable is 4 to 10 mm ($6/32$ " to $25/64$ ") as shown in Fig. 3-1.
3. If necessary, adjust the height of the tonearm lifting platform by loosening the tonearm height adjustment screw as shown in Fig. 3-3.

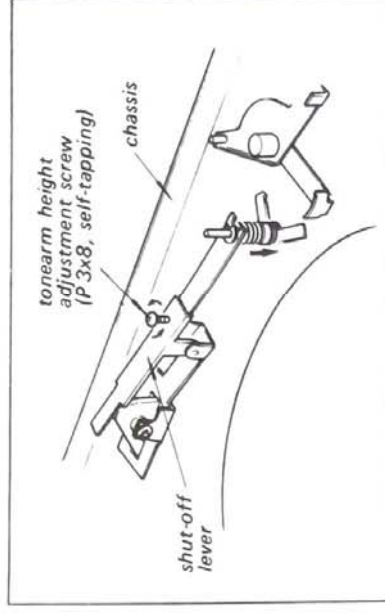

Fig. 3-3. Tonearm height adjustment

3-2. AUTOMATIC RETURN POSITION ADJUSTMENT

1. Release the tonearm from its rest.
2. Loosen the allen-head screw, and adjust the tonearm lever so that the tonearm lever is in parallel to the edge of chassis as shown in Fig. 3-4.
3. The position where the tonearm starts to return can be adjusted by turning the automatic return position adjustment screw shown in Fig. 3-4.
If the automatic return works too early, turn the adjustment screw clockwise — if too late, turn the screw counterclockwise.

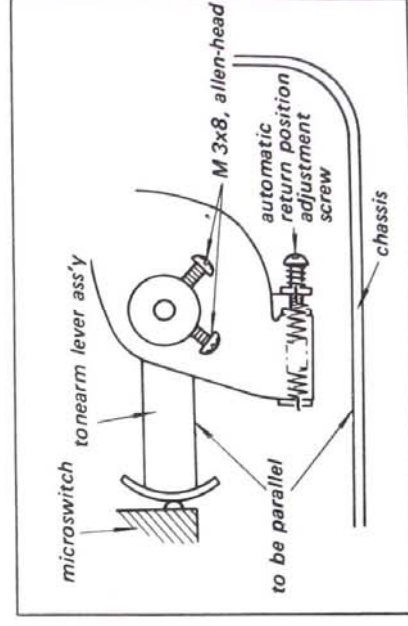

Fig. 3-4. Automatic return position adjustment

3-3. STYLUS FORCE ADJUSTMENT

Preparation

1. Release the tonearm from its rest.
2. Horizontally balance the tonearm by turning the counter weight at the rear of the tonearm, and set the stylus force gauge ring to "0" while holding the counter weight as shown in Fig. 3-6.

Supplied Cartridge (VM-26G)

Adjust the stylus force by turning the counter weight to obtain "2 g" reading on the stylus force gauge as shown in Fig. 3-5.

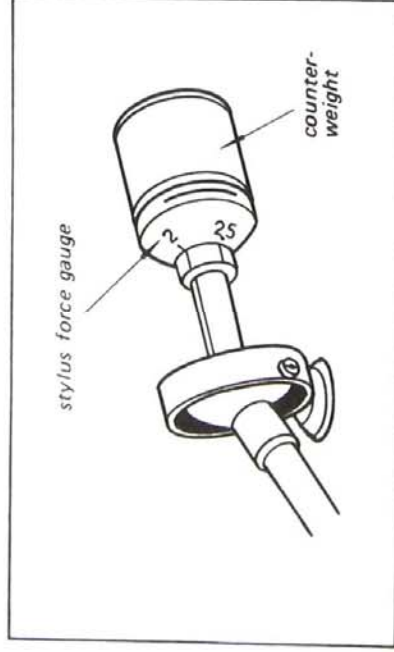

Fig. 3-5. Stylus force adjustment

Other Cartridge

1. Check the instructions given with the cartridge to determine the proper stylus force. Each graduation on the stylus force gauge represents 0.5 gram.
2. Adjust the stylus force by turning the counterweight to obtain the proper (recommended) value of stylus force.

3-4. ANTI-SKATING FORCE ADJUSTMENT

Preparation

1. Release the tonearm from its rest, and set the cueing lever to the "V".
2. Horizontally balance the tonearm by turning the counterweight at the rear of the tonearm, and set the stylus force gauge ring to "0" while holding the counterweight as shown in Fig. 3-6.

Procedure

Supplied Cartridge (VM-26G)

1. Turn the counterweight counterclockwise to obtain the "2 g" reading stylus force gauge as shown in Fig. 3-5.
2. Adjust the anti-skating force by matching its left side to the center (2 g) of the three lines on the anti-skating force gauge as shown in Fig. 3-7.

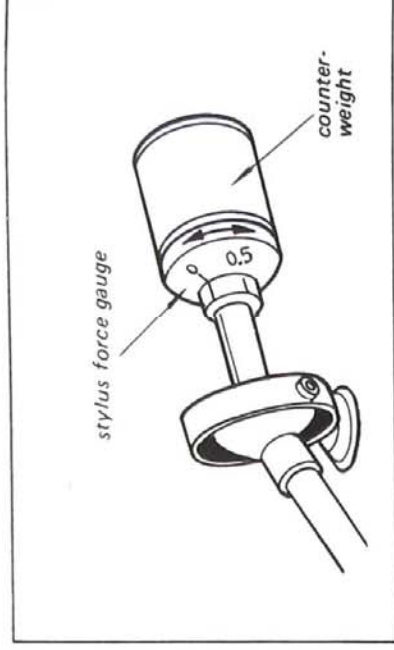

Fig. 3-6. Longitudinal balance adjustment

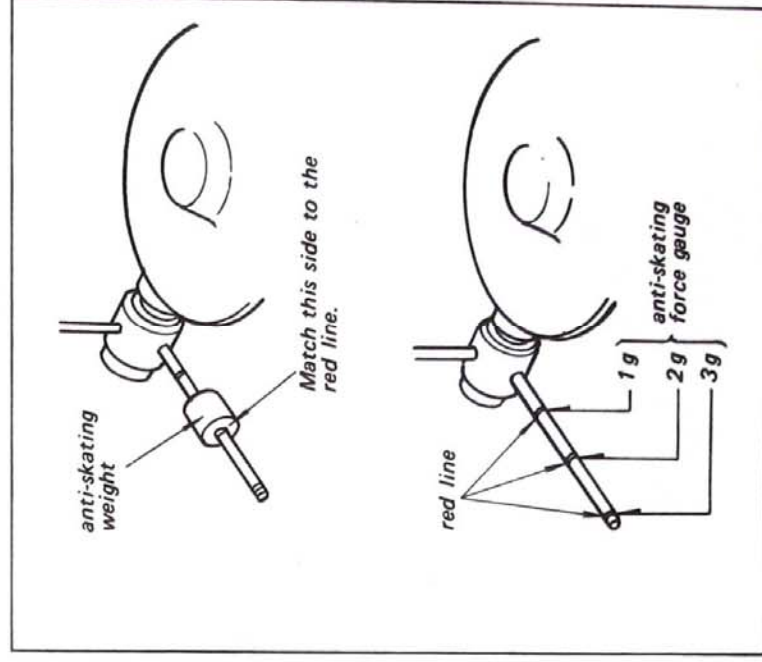

Fig. 3-7. Anti-skating force adjustment

Other Cartridge

1. Check the instructions given with the cartridge to determine the proper stylus force.
2. Turn the counter weight counterclockwise to obtain the proper (recommended) value of stylus force.
3. Set the anti-skating gauge to the same value set in step 2.

Note: For specific anti-skating force falling between two lines (for instance 1.5 g, etc.), slide the weight to the left or right to set it to the corresponding position between the lines as shown in Fig. 3-7.

When using a cartridge having a stylus force of less than 1 gram, take off the anti-skating weight.

3-5. MICROSWITCH POSITION ADJUSTMENT

1. Place the tonearm on the its rest.
2. Set the microswitch to "OFF" by turning the adjustment screw shown in Fig. 3-8.
3. When the tonearm is removed from its rest, check to see that the microswitch is "ON".
4. Repeat the above step 2 and 3, if necessary.
5. When the tonearm starts to return in automatic return operation, confirm that the microswitch is "OFF".

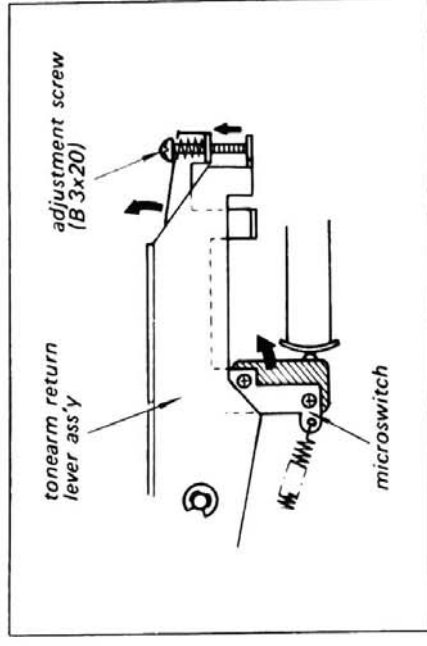

Fig. 3-8. Microswitch position adjustment

SECTION 4 MAINTENANCE

4-1. ADAPTATION TO LOCAL LINE FREQUENCY

Note: The PS-5100 can be adapted to operate at the another ac local line frequency by replacing the motor pulley, the motor starting capacitor and by changing the wiring of motor.

Motor Pulley Replacement

Refer to table 4-1 to determine the part number of the proper pulley.

TABLE 4-1. MOTOR PULLEYS

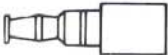
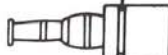
| Motor Pulleys | |
|---|---|
| For 50 Hz | For 60 Hz |
|  [Part No. X-48274-15-0] |  [Part No. X-48274-16-0] |

Procedure

1. Remove the turntable base as described in Procedure 2-2.
2. Remove the motor pulley by loosening the set screw.
3. Install the replacement pulley, and set the speed selector knob to 33 rpm position.
4. Adjust the height of the motor pulley so that the top of motor pulley is even with the top edge of speed selector lever as shown in Fig. 4-1.

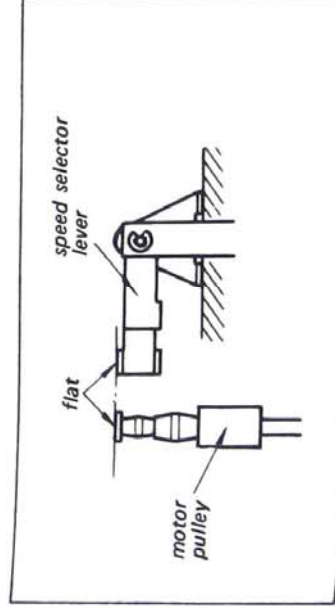

Fig. 4-1. Motor pulley height adjustment

Motor Starting Capacitor Replacement

Match the value of starting capacitor to local line frequency as follows:

| Description | Part No. |
|-------------------------------------|---------------|
| 50 Hz 1 μ F 250V MP capacitor | 1-1113-148-11 |
| 60 Hz 0.7 μ F 250V MP capacitor | 1-1113-149-11 |

Motor Wiring Change

To obtain proper operation, the motor wiring must also be changed.

1. Remove the self-tapping screw securing the 4-P AMPLOK plug to the chassis, and change the wiring to match the local line frequency as shown in Fig. 4-2.

Note: To remove the lead wire from the 4-P AMPLOK, press the terminal tip with tweezers, then push it out as shown in Fig. 4-3.

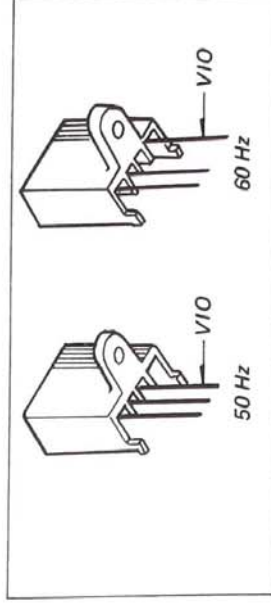

Fig. 4-2. Motor wiring change

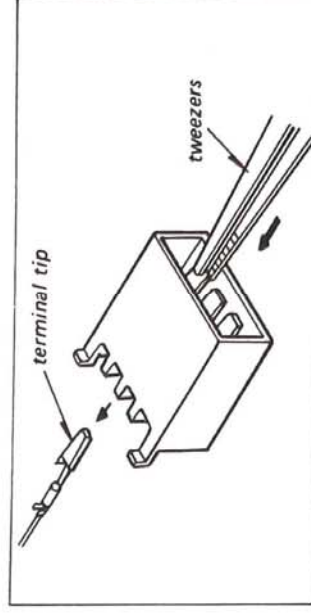

Fig. 4-3. Lead wire removal

4-2. LUBRICATION

Apply two or three drops of oil to the shaft of the turntable and motor once a year. Avoid excessive lubrication. It will cause slippage of the mechanism. If the oil should spill the surface of the motor pulley and the turntable drive surface, wipe it immediately with a soft cloth moistened with denatured alcohol.

SECTION 5 REPACKING

The original shipping carton and packing materials are the ideal containers for shipping the unit. However to secure the maximum protection, the

unit must be repacked in these materials precisely as before. The proper repacking procedures are shown in Fig. 5-1.

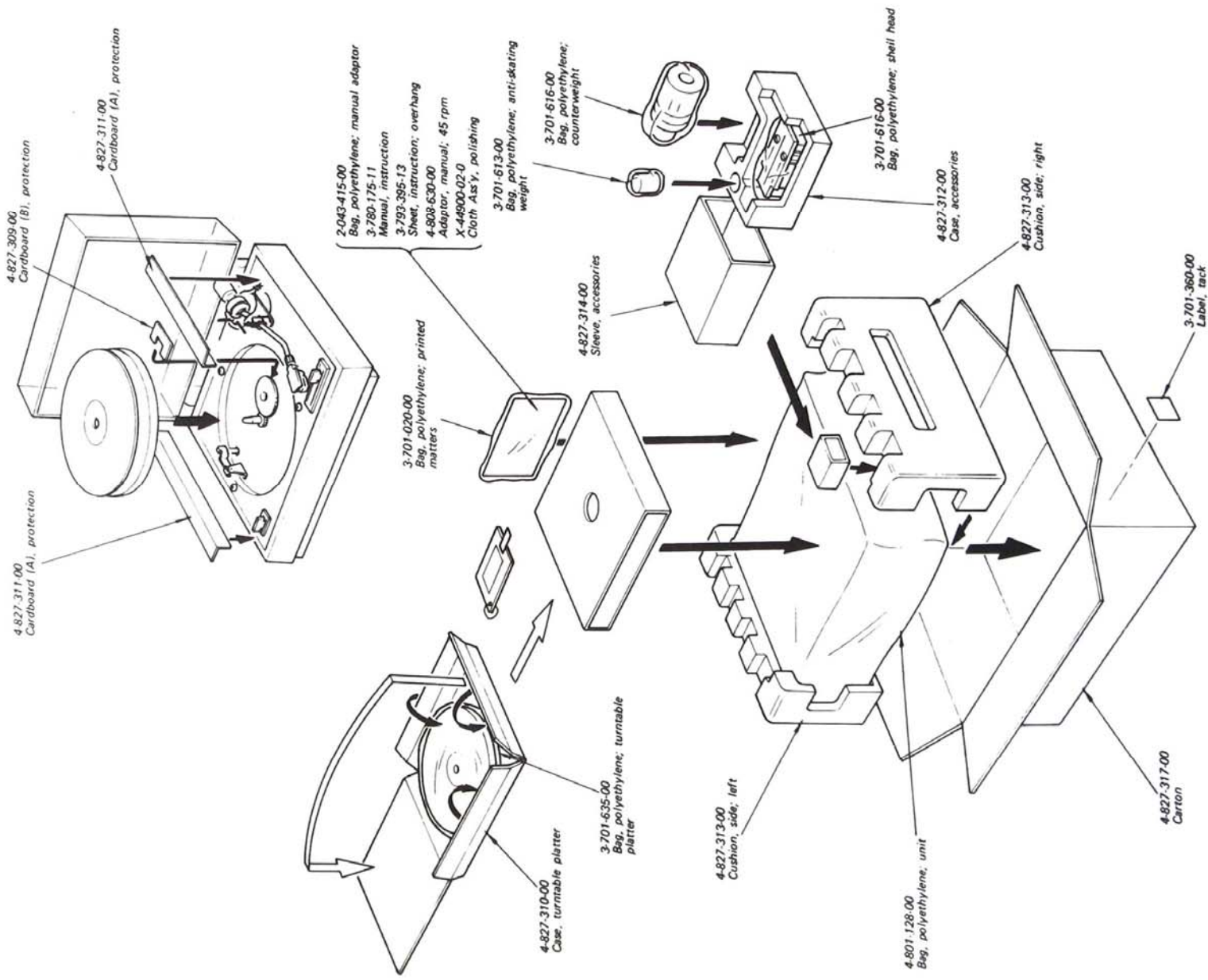
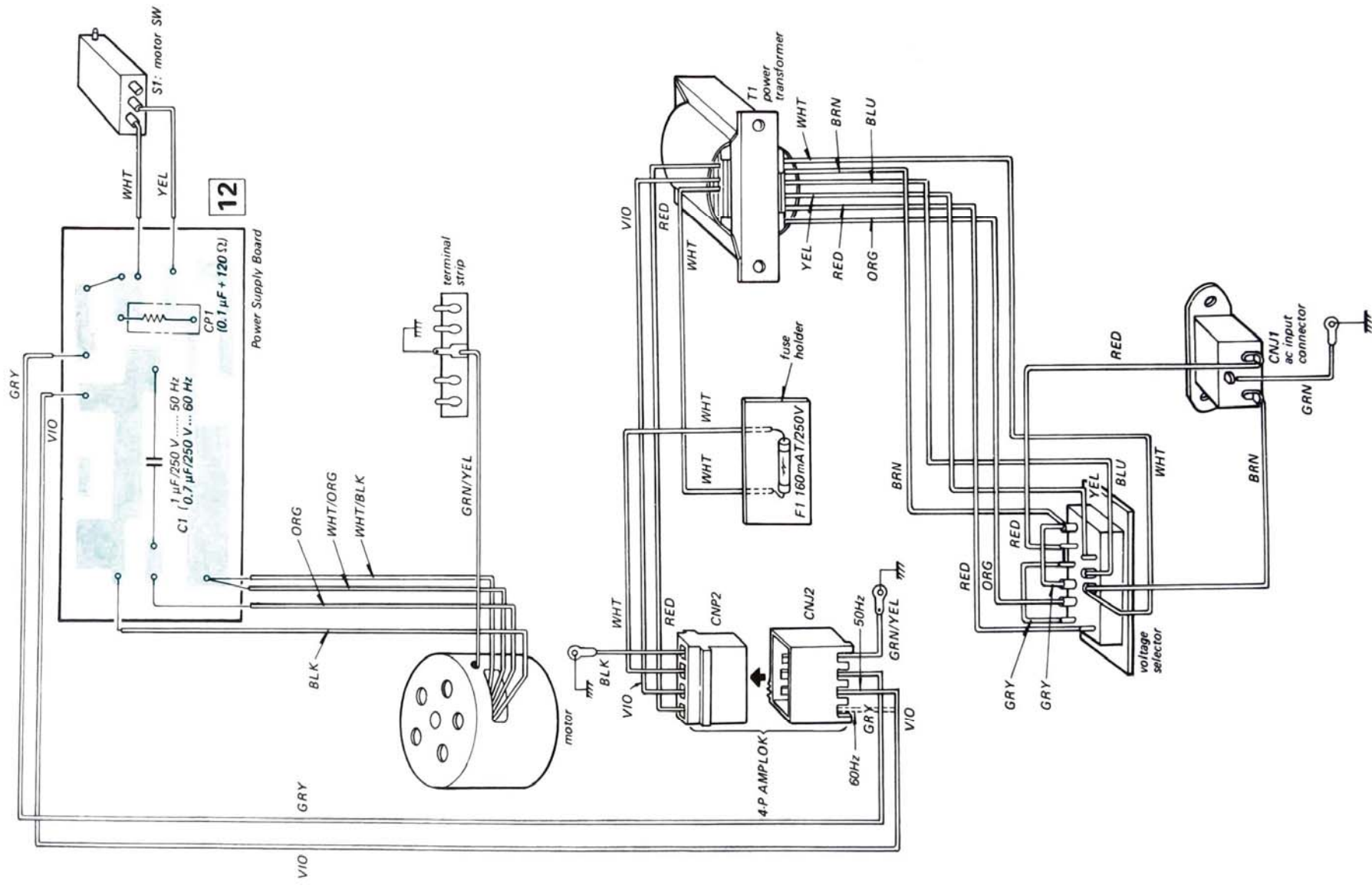

Fig. 5-1. Repacking

SECTION 6 DIAGRAMS

6-1. MOUNTING/WIRING DIAGRAM



6-2. SCHEMATIC DIAGRAM

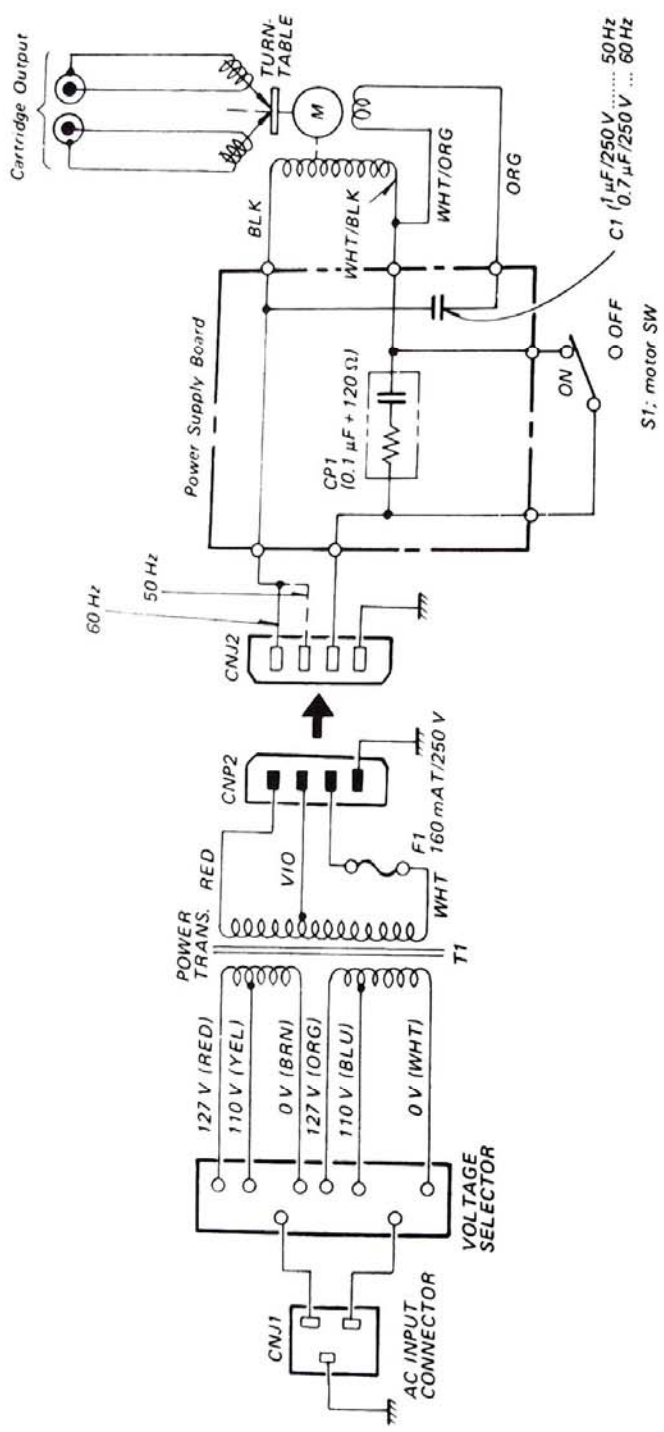

SECTION 8 ELECTRICAL PARTS LIST

| <u>Ref. No.</u> | <u>Part No.</u> | <u>Description</u> | <u>Ref. No.</u> | <u>Part No.</u> | <u>Description</u> |
|-----------------|-----------------|---|-----------------|-----------------|--|
| CPI | 1-101-534-00 | encapsulated component, 0.1 μF + 120 Ω | S1 | 1-514-093-00 | microswitch (MOTOR) |
| | 1-113-148-11 | capacitor, metalized paper; 1 $\mu\text{F}/250\text{ V}$ | F1 | 1-532-215-00 | fuse, 160 mA/T/250 V holder, fuse |
| C1 | | | 1-113-149-11 | 1-533-083-00 | cord, phono; with phono plug |
| | 1-534-785-00 | amplok, 4-P (jack) | | | |
| T1 | 1-441-815-00 | motor starting (for 50 Hz) | CN12 | 1-536-080-00 | terminal strip, 2L2 (C) |
| | | capacitor, metalized paper; 0.7 $\mu\text{F}/250\text{ V}$ | | 1-536-398-00 | stylus tip, ND-132G |
| CNP2 | 1-508-478-00 | transformer, power | | 1-549-064-00 | cartridge, VM-26G |
| | 1-509-385-00 | amplok, 4-P (plug) | | 1-581-882-00 | printed circuit board, power supply |
| CNJ1 | 1-509-445-00 | selector, voltage | M | 8-831-414-00 | motor, 4-pole; hysteresis synchronous, HC-414 |
| | | connector, ac input; 3-P | | | |